



OneStop+™

Anti-scale systems



Features

- Prevents scaling by converting limescale into harmless crystals
- Retains essential minerals
- Reduces existing limescale deposits
- Environmentally friendly
- No electricity or salt required
- No regeneration or backwash required
- Easy to install, no maintenance required
- Increases the efficiency of boilers and other hot water appliances
- Reduces heavy metals such as copper, lead, mercury, zinc, and cadmium

The OneStop+™ system provides protection from scale formation on internal and external plumbing surfaces. Additionally, it reduces heavy metals such as copper, lead, mercury, zinc, and cadmium. It can be installed at the point of entry to a building to treat both hot and cold-water, or it can be located directly before a water heater, boiler, or other water using device that requires protection from hard water.

OneStop+ prevents scale by transforming the normal dissolved hardness minerals into undissolved crystal microparticles. These crystals stay suspended in the water and have a greatly reduced ability to react and attach to surfaces like dissolved hardness does. Therefore, the problem of internal build-up of scale in pipes, water heaters, boilers, espresso and coffee machines, fixtures and glass is greatly reduced.

OneStop+ is not a water softener – water treatment chemistry “e.g. antiscalants, sequestrants, etc.” will most likely have to be changed to be compatible with OneStop+ treated water. Laundry and dishwashing chemistry will likewise require adjustments.

OneStop+™ Working Principle

1. The media attracts dissolved calcium carbonate (CaCO_3) and magnesium carbonate (MgCO_3) scale molecules into “templates” on the media.

2. The calcium carbonate (CaCO_3) and magnesium carbonate (MgCO_3) scale molecules grow into microscopic crystals.

3. The crystals detach when they are too large to be held by the OneStop+ media. These harmless crystals effectively isolate the calcium carbonate (CaCO_3) and magnesium carbonate (MgCO_3) scale molecules from the water and anything the water comes in contact with.

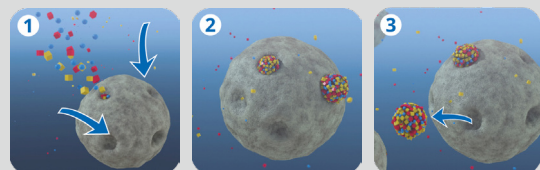

Where Water Gets Better

Models

Model Number	Connection	Rated Service Flow		Intermittent Peak Flow	Dimensions (mm)		Dry Weight (kg)	Replacement Cartridge
		lpm	gpm		A	B		
Filter Housing Systems								
OSP-10SB OSP-10SN	3/4" BSPP / NPT	3	0.8	5 lpm / 1.3 gpm	326	115	1.4	OSP-10SR
OSP-10JB OSP-10JN	3/4" BSPP / NPT	8	2	12 lpm / 3.2 gpm	356	183	4.5	OSP-10JR
OSP-20JB OSP-20JN	3/4" BSPP / NPT	15	4	22 lpm / 5.8 gpm	621	183	6.3	OSP-20JR

Specifications

Product Series Name	OneStop+™ - Housing System
Min. Operating Temperature	4°C / 40°F
Max. Operating Temperature	40°C / 104°F
Max. Operating Pressure	8.6 bar 125 psi

Models

Model Number	Connection	Rated Service Flow		Dimensions (mm)		Dry Weight (kg)	Replacement OSP Media (L)
		lpm	gpm	A	B		
Media Tank Systems							
OSP-1024B OSP-1024N	1" BSPP/ NPT	50	13	655	264	8.7	3.5
OSP-1054B OSP-1054N	1" BSPP/ NPT	76	20	1435	264	15.0	5.0
OSP-1252B OSP-1252N	1" BSPP/ NPT	114	30	1390	311	19.1	7.5
OSP-1465	2" PVC Socket	189	50	1900	360	33.6	12.5
OSP-1665	2" PVC Socket	303	80	1900	400	47.5	20.0

Refer to technical data sheet for detailed information

Specifications

Product Series Name	OneStop+™ - Media Tank System
Min. Operating Temperature	4°C / 40°F
Max. Operating Temperature	49°C / 210°F
Min. Operating Pressure	1 bar 15 psi
Max. Operating Pressure	10 bar 150 psi

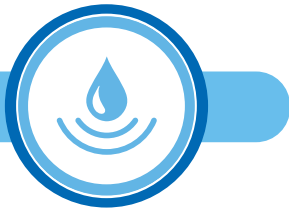

OneStop+™

Anti-scale systems

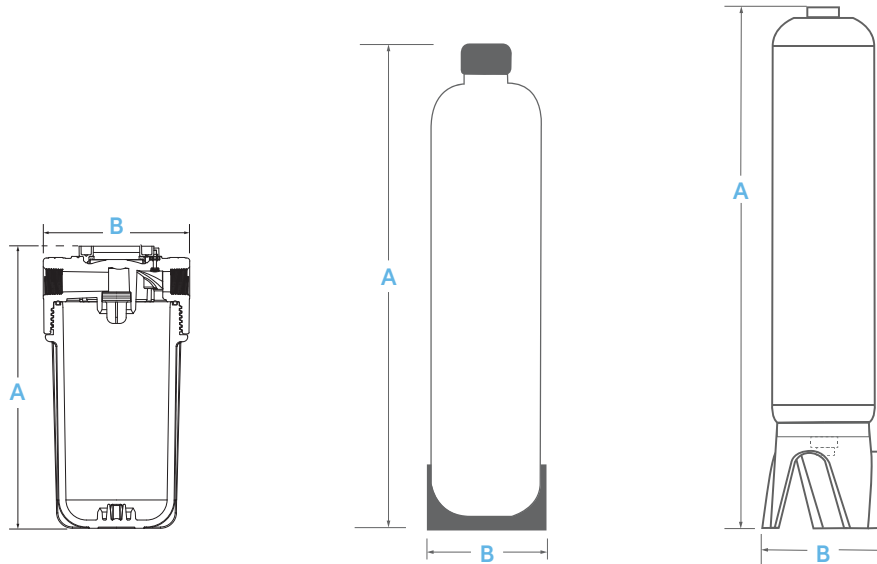

Equipment specifications

OneStop+™ systems are complete, self-contained anti-scale systems. A simple inlet and outlet connection is all that is required for installation. Filter housing systems are preloaded with media cartridges and ready to use. Media tank systems are shipped with the OSP media separate, so there is a need to fill the media before installation.

Usage

Prior to installation, please check system pressure, temperature, and water chemistry to ensure the application is compatible with the OneStop+ specifications.

Water chemistry limitations*

pH	6.5 - 8.5
Maximum Hardness	1300 ppm
Chlorine, Max	< 3 ppm
Ferrous Iron, Max	0.3 ppm
Manganese, Max	0.05 ppm
Calcium Sulphate (CaSO ₄)	> 300 ppm, Treat Before OneStop+
Oil and Polyphosphates	Treat Before OneStop+
Hydrogen Sulfide	Treat Before OneStop+
Phosphate (PO ₄)	< 0.3 ppm: Activated Carbon Prefiltration Recommended > 0.3 ppm: Activated Carbon Prefiltration Required

* Cartridge life may vary from 18 to 24 months do to feed water chemistry.